



O6 ::

## QUICK START GUIDE

Get started quickly with your O6

## Contents

Getting Started	4
Quick Start	4
O6 Device Overview	5
Using your O6 Device	7
Controlling your O6	7
O6 Modes	7
O6 Basic Mode	7
O6 Advanced Mode	9
Enabling the VoiceOver shortcut on your iPhone (setup only needed once)	9
Turning VoiceOver on and off	9
Navigating Apps in Advanced mode	10
Using the O6 App	11
Using O6 with the O6 App	11
O6 App Channels	11
Performing Actions using O6	12
Overview of how Actions Work	13
O6 Accessories	14

## Overview

Congratulations on owning an O6, an entirely new way to stay connected without looking at or touching your phone.

The world has changed drastically in the last 10 years. With ubiquitous Wi-Fi and robust cellular plans, we have gone from “work phones” and desktop computers to being always connected, whether we are walking to work or the grocery store, working out or even driving.

People’s dependence on smartphones is utterly complete. Unfortunately, this dependence does not end when we step outside or open a car door. At this very moment, over 660,000 Americans are handling their phones - checking email, scrolling through twitter - while driving.

We can’t stop people from feeling the need to check their email and social media, but O6 does something that no other product can do - it allows them to do it without taking their eyes off the road - as simply and easily as they flip through radio stations in their car. O6 demonstrates a keen awareness of aesthetic form, precision engineering and craftsmanship that produces a very satisfying touch experience. The moment you hold the O6 in your hand, you’ll notice the quality and care that has gone into making this product.

Our goal is to make driving and even walking safer, one O6 at a time.



reddot award 2017  
winner

## Getting Started

### Quick Start

1. Charge O6 until the light turns blue.

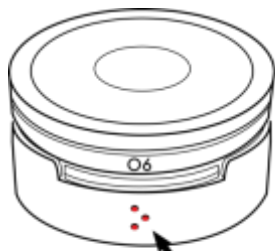

Red>Charging.

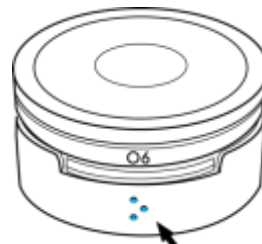

Blue>Charged.

2. Download the “O6 Free Your Eyes” app from the App Store and log into your various channel accounts (e.g. email, Twitter, etc).



O6: Free Your Eyes  
Fingertips Lab, Inc.



3. Pair your phone and O6 via Bluetooth.
  - Open the Bluetooth settings on your iPhone.
  - Click the **Center** button on your O6.
  - Tap **O6** on the phone screen and then tap **Pair**.



*TIP: Your keyboard might be disabled once your phone is paired with O6. Watch this [video](#) to see how to bring back your keyboard.*

## O6 Device Overview

You can watch videos of setting up and using O6 [here](#).

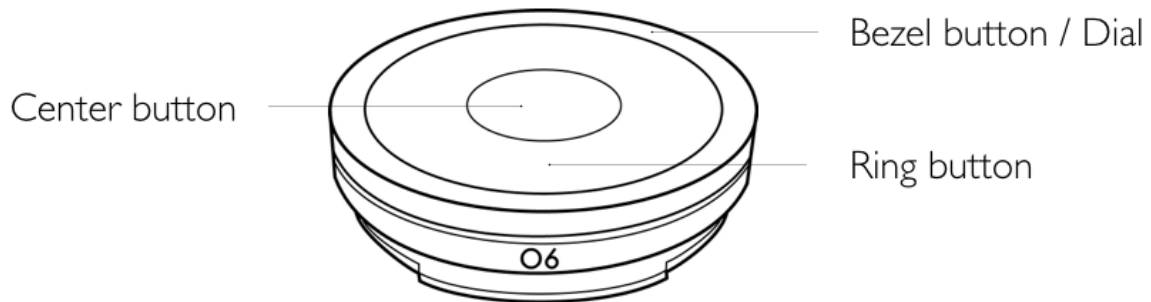

Your O6 lets you choose channels “eyes-free” through speech feedback. In addition, it has a multi-functional bezel dial and two tactile buttons:

- **Center button** – The button at the Center of the device is called the Center button. This button has a sunk profile and a thin wall separates the edges of this button from the neighbouring button.



- **Ring button** – The donut shaped button around the Center button. It is one uniform button and it performs the same action no matter where you click on the ring. This hallmark design results in its orientation independence.



- **Bezel button / dial** – The thin peripheral metal dial is called the Bezel dial. As a dial, it is used to scroll through lists, such as menu items or emails.

This dial also acts as a button, though in most of the O6 modes, the Ring and Bezel buttons are programmed to perform the same function. Their functionality can be separated in the advanced modes (more on this later).

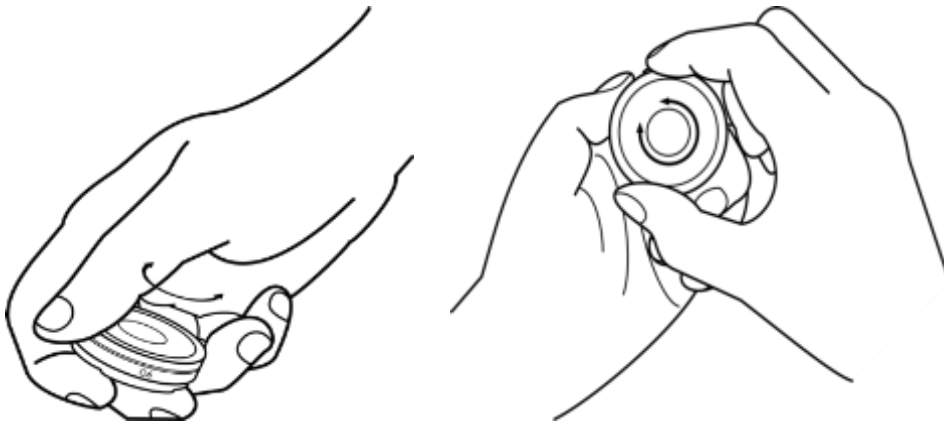

- You Press and Rotate the **O6** bezel dial

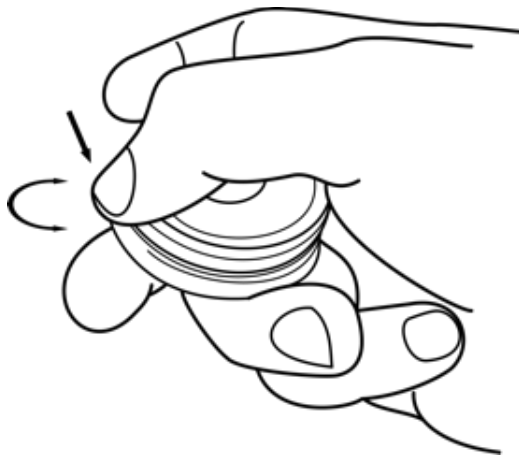

## Using your O6 Device

### Controlling your O6

These controls can be used in multiple ways to achieve a range of functionality:

- **Single-click the Center button** – Selects item. Plays/Pauses music, select a menu item in the O6 App, or Plays/Pauses a content item, such as an email, in the O6 App.
- **Double-click the Center button** – Brings up Actions in the O6 App.
- **Single-click the Ring button or Bezel dial** – Takes you back to the main menu in the O6 app, allows you to escape or exit the Actions menu in the O6 App.
- **Turn Bezel Dial Clockwise or Counter Clockwise** – Next or Previous track.
- **Press the Bezel or Ring dial and turn clockwise or counter clockwise**– Increase or decrease volume.

### O6 Modes

O6 is a versatile controller that contains many modes, for example:

- **Basic Mode** – This is the default mode that will be active upon receiving your O6. It is used to control your music and media apps, including the O6 app.
- **Advanced Mode** – This is used to control your iPhone using iOS VoiceOver.

You can switch between modes by triple-clicking the HOME button (requires iPhone HOME button triple-click accessibility shortcut set to iOS VoiceOver) on your iPhone. Haptic buzzes indicate mode transitions. A haptic feedback buzz indicates the mode you are in:

- **A single haptic buzz** – Indicates you have entered the Basic Mode.
- **Double haptic buzz** – Indicates you have entered the Advanced Mode.

**Tip:** The O6 app must be active, either in the foreground or in the background, for the O6 device to complete a mode transition. Please bring the O6 app to the foreground if you do not detect haptic buzzes associated with an expected mode change.

### O6 Basic Mode

You can use O6 to remotely control your favorite music or media apps, such as Spotify, Apple Music, Podcasts, Audible, Netflix, YouTube, Amazon Video, and more. The default

mode in O6 is called the Basic Mode, which is used to control Music, Podcasts, and the O6 App.

Open any media app, such as Spotify, Pandora, Apple Music, Podcasts, Audible, or similar and explore the functionality listed.

Table 1. Actions and their results in Basic mode to control music.

<b>ACTION</b>	<b>RESULT</b>
<b>SINGLE-CLICK THE CENTER BUTTON</b>	Toggles Play/Pause for the media.
<b>TRIPLE-CLICK THE CENTER BUTTON</b>	Unhide the onscreen keyboard
<b>TURN THE BEZEL DIAL ONE CLICK</b>	Clockwise switches to the next track. Counter-clockwise switches to the previous track.
<b>PRESS BEZEL AND TURN DIAL CLOCKWISE OR COUNTER CLOCKWISE</b>	Increase or Decrease Volume
<b>TRIPLE-CLICK THE RING BUTTON</b>	(Optional) Switches the O6 dial to control the volume. The transition to volume mode is indicated by a ramp-up haptic buzz and the dial can then be used to adjust the volume. Switch O6 back to Basic Mode by triple-clicking the Ring button again.

Table 2. Actions and their results in Basic mode to control the O6 App.

<b>ACTION</b>	<b>RESULT</b>
<b>SINGLE-CLICK THE CENTER BUTTON</b>	Select a channel or toggles Play/Pause track
<b>DOUBLE-CLICK THE CENTER BUTTON</b>	Bring up Actions in the Email channel
<b>TRIPLE-CLICK THE CENTER BUTTON</b>	Unhide the onscreen keyboard
<b>SINGLE-CLICK THE RING BUTTON</b>	Go back to main channel menu or exit the actions menu
<b>TURN THE BEZEL DIAL ONE CLICK</b>	Clockwise switches to the next channel or track. Counter-clockwise switches to the previous channel or track.
<b>PRESS BEZEL AND TURN DIAL CLOCKWISE OR COUNTER CLOCKWISE</b>	Increase or Decrease Volume
<b>TRIPLE-CLICK THE RING BUTTON</b>	(Optional) Switches the O6 dial to control the volume. The transition to volume mode is



indicated by a ramp-up haptic buzz and the dial can then be used to adjust the volume. Switch O6 back to Basic Mode by triple-clicking the Ring button again.

## O6 Advanced Mode

Advanced Mode is a powerful mode for remotely controlling any of your existing apps with or without visual attention. This mode is intended for more advanced users and leverages the iOS VoiceOver feature.

### Enabling the VoiceOver shortcut on your iPhone (setup only needed once)

Before you can use these modes, you need configure iOS VoiceOver as follows:

1. Tap **Settings** on your iPhone home screen.
2. In **Settings**, navigate to **General > Accessibility > Accessibility Shortcut**
3. In **Accessibility Shortcut**, under **TRIPLE-CLICK THE HOME BUTTON**, tap **VoiceOver**.

### Turning VoiceOver on and off

To turn VoiceOver on or off, you can either:

- Triple-click your iPhone **Home** button.
- Triple-click the **Ring** button on your O6 device when it is in Advanced mode.

**Tip:** In this mode, normal touchscreen interaction is disabled. You must turn Off VoiceOver on your phone to resume normal touchscreen gestures.

The image below describes the functions of O6 in Advanced mode.

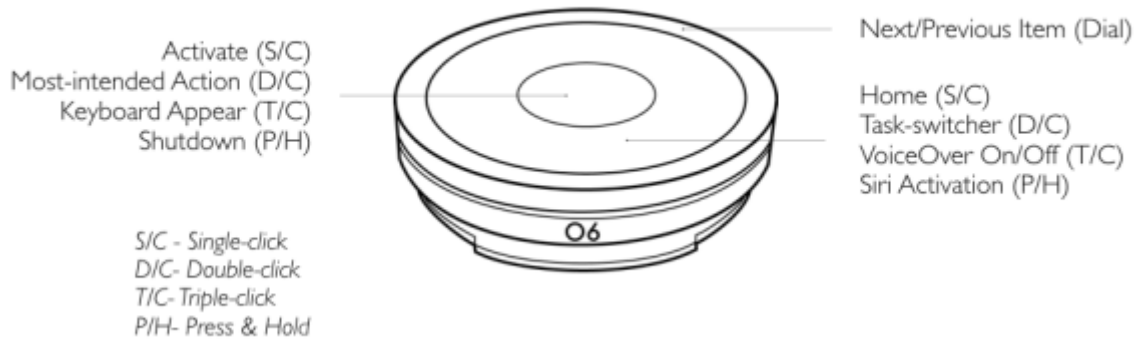

### Navigating Apps in Advanced mode

Table 2. Actions and their results in **Advanced** mode.

ACTION	RESULT
Single-click the Ring or Bezel button	Go to HOME screen, or go to folder if the App is in a folder.
Triple-click the Ring or Bezel button	Next Horizontal Screen
Single-click the Center button	Open app or activate item in focus
Double-click the Center button	Performs the most likely action, such as <b>answering an incoming phone call</b> , or <b>Play/Pause music, podcast, or audiobook</b> when on HOME screen or in media app, <b>taking a picture</b> when in the Camera app, or opening <b>Facebook Actions</b> when in Facebook, and so on.
Triple-click the Center button	Toggle the <b>on-screen Virtual Keyboard</b> . The text field needs to be in focus to activate this setting. <i><b>Tip:</b> The on-screen virtual keyboard disappears when O6 is connected. You can show (or hide) the virtual keyboard by using this functionality.</i>
Press and hold the Center button for 5 seconds until you feel double haptic buzz	Shutdown O6. Click any button to wake O6 and reconnect.
Single-click the bezel dial clockwise	Next app on Home screen, App folder, or task switcher; or move focus to next onscreen item.

ACTION	RESULT
Single-click the bezel dial counter-clockwise	Previous app on Home screen, App folder, or task switcher; or move focus to previous onscreen item.

***Tip:** It is best to turn Quick Nav ON to get a few of the features to work. You can turn Quick Nav on by connecting an external wireless keyboard to your iPhone and simultaneously pressing the Left and Right arrow. Alternatively, please refer to the Media & Settings mode section in the User Manual for how to turn Quick Nav on using only O6.*

## Using the O6 App

### Using O6 with the O6 App

You can use O6 to navigate and perform the following tasks in the O6 App:

- **Select a channel** – Click the Center button to select a channel (e.g., email, Twitter, NPR One).
- **Toggle Play/Pause** – Within a channel, click the Center button to Play/Pause.
- **Go to the next item** – Rotate the dial clockwise to go to the next item.
- **Go to the previous item** – Rotate the dial counter-clockwise to go to the previous item.
- **Bring up the Actions menu** – Within a channel, double-click the Center button to bring up the Actions menu.
- **Go back to the Main menu or exit the Actions menu** – Click the Ring button to go back to the Main menu or to exit the Actions menu to resume content playback.

***Tip:** The O6 App runs in the background, even when the phone is locked. With a little practice, you can use O6 without looking at your phone!*

### O6 App Channels

The O6 App consists of channels that narrate the content to you as audio. The current list of channels includes email, Twitter, Notifications, NPR One, Pocket, Contacts, and Settings. We are continuously adding new channels so you will see your favourite apps appear in your channels list over time.



Each channel consists of individual content such as emails or Tweets arranged as a list sorted by time with the most recent content at the top of the list. The bar at the bottom of the screen shows the item that is currently playing or in focus in the list.

You can do the following:

- Tap on any content to toggle **Play/Pause** of the audio playback.
- Tap on the **Play/Pause icon** on the bar to resume or pause audio playback.
- Tap on the **circle with three dots** to bring up the **Actions Menu**.
- Tap on the **Up arrow** to reveal a **detailed view of the content** being displayed.

## Performing Actions using O6

Actions are a powerful feature of the O6 experience. When you receive a text or email message, you may need to respond quickly, for instance, to reply Yes or No, or to take a specific action like getting directions to a new address. Such interactions typically require you to look at your phone, type, and open and switch between apps. This is inconvenient and dangerous while driving.

With O6, there is no need to touch, type, or even look at your screen. You can double-click the Center button in the email channel to bring up Actions. Simply turn your O6 dial and the device will scroll through and narrate possible action options aloud until you select one of them by clicking the Center button again.

Actions enable you to:

- **Respond to messages (texts, emails) with a choice of predetermined responses.**

- **Answer/make phone calls.**

O6 automatically extracts names and phone numbers from a message, enabling you to make a phone call as one of the predetermined action options.

- **Get directions using your favorite maps app.**

O6 extracts addresses from messages, allowing you to automatically navigate to important locations via commonly-used map apps (e.g., Google or Apple Maps).

The range of actions keeps on expanding!

## Overview of how Actions Work



With O6, you can listen to a message — “eyes free”. But how do you respond without looking at or touching your phone? How do you start your maps application and get navigation directions to the new address, without even looking at the phone?

To answer these questions, consider a scenario where O6 is reading a message aloud and you decide that you would like to perform an action. You can do this by doing the following:

1. Double-click the **Center** button on your O6.

2. O6 presents a list of the most-likely actions based on your message content.
3. Scroll through the list of actions by turning the bezel dial.  
O6 narrates each action as you scroll.
4. Click the **Center** button to select an action and O6 will perform it, for example sending a message or starting the maps app with the navigation directions.

Actions reduce complex interactions involving multiple apps, typing, and unnecessary steps to simple interactions!

## O6 Accessories

O6 accessories are sold separately at [o6app.com](http://o6app.com). New accessories will be added over time, so please check [o6app.com](http://o6app.com) to stay updated.

There are two optional accessories currently available:

- The Steering Wheel Mount



- The Clip Mount

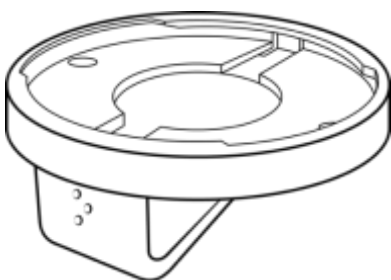

Note that your O6 only fits into the Steering Wheel Mount and the Clip Mount when it is correctly aligned and in the correct orientation. Please refer to [User Manual or online video tutorials](#) for detailed descriptions. Here are some of the ways to use O6 in your car.

